

PTN LOT 663

BOOK 11 PAGE 16
 N89°43'02"E, 173.61'

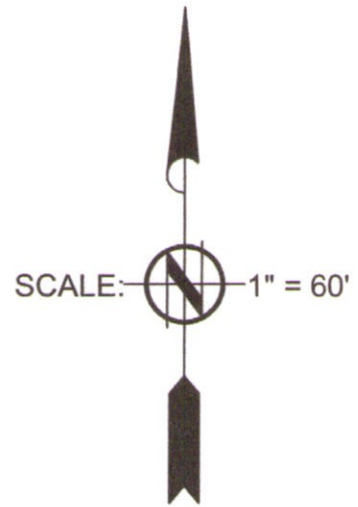
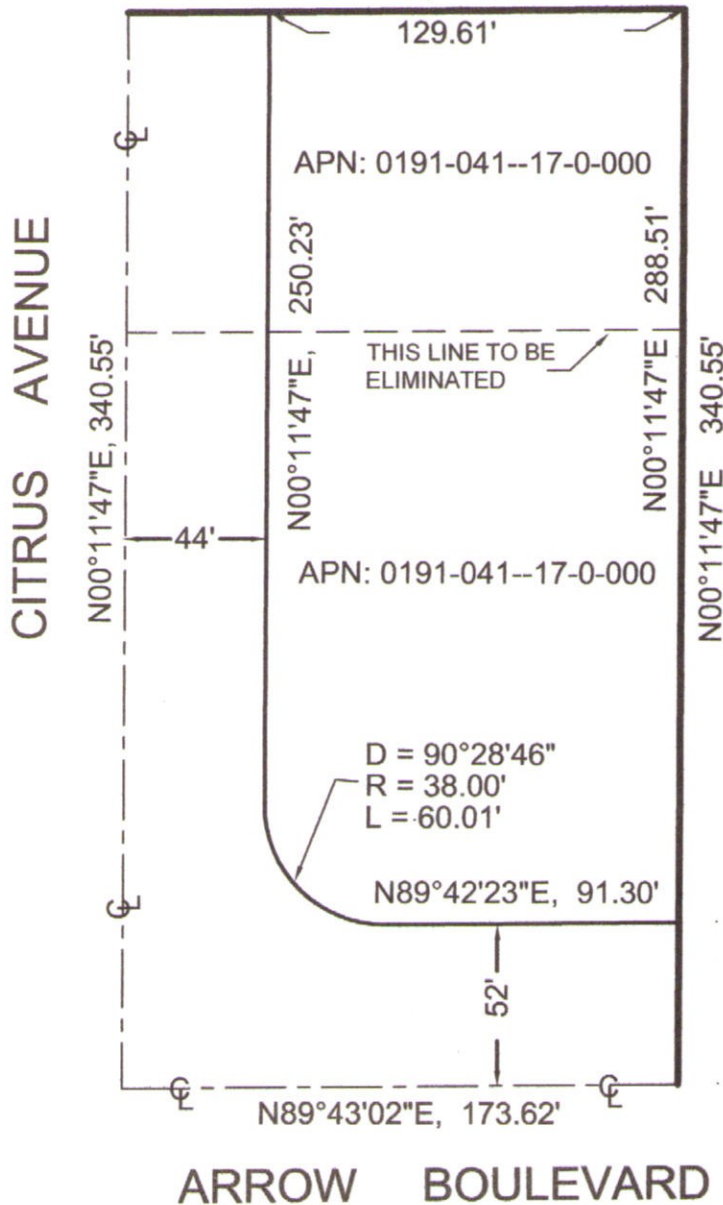

PTN LOT 663
 BOOK 11 PAGE 16

RICHARD L. BEIGLE
 LICENSED LAND SURVEYOR
 67 MIRA COLLADO
 SAN CLEMENTE, CA 92673
 TELE: 949-510-2101 FAX: 949-388-4294
 e-mail: richbeigle@cox.net

LEGAL DESCRIPTION

ALL OF FARM LOT 663 PER MAP FILED IN BOOK 11 OF MAPS AT PAGE 12, RECORDS OF SAN BERNARDINO COUNTY, CALIFORNIA, EXCEPT THEREFROM THE EAST 17.30 ACRES, THE NORTH 317 FEET AND THE SOUTH 274 FEET OF THE WEST 2.62 ACRES.

TOGETHER WITH THE SOUTH 274 FEET OF THE WEST 2.62 ACRES OF SAID FARM LOT 663

